

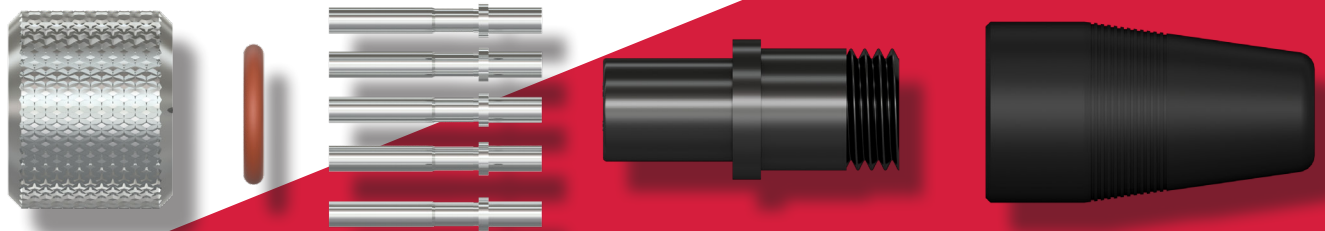

VIBRATION ANALYSIS HARDWARE



"M" Series M12-Style Connector Kits
Product Manual

TABLE OF CONTENTS

- Introduction.....3
- Assembly for M2X Series.....5
- Assembly for M3X Series.....8
- Assembly for M4X Series..... 11
- Maintenance..... 14
- Warranty & Return Information 14



INTRODUCTION

This document contains information on the operation, installation and maintenance of the M-style series of connector kits.

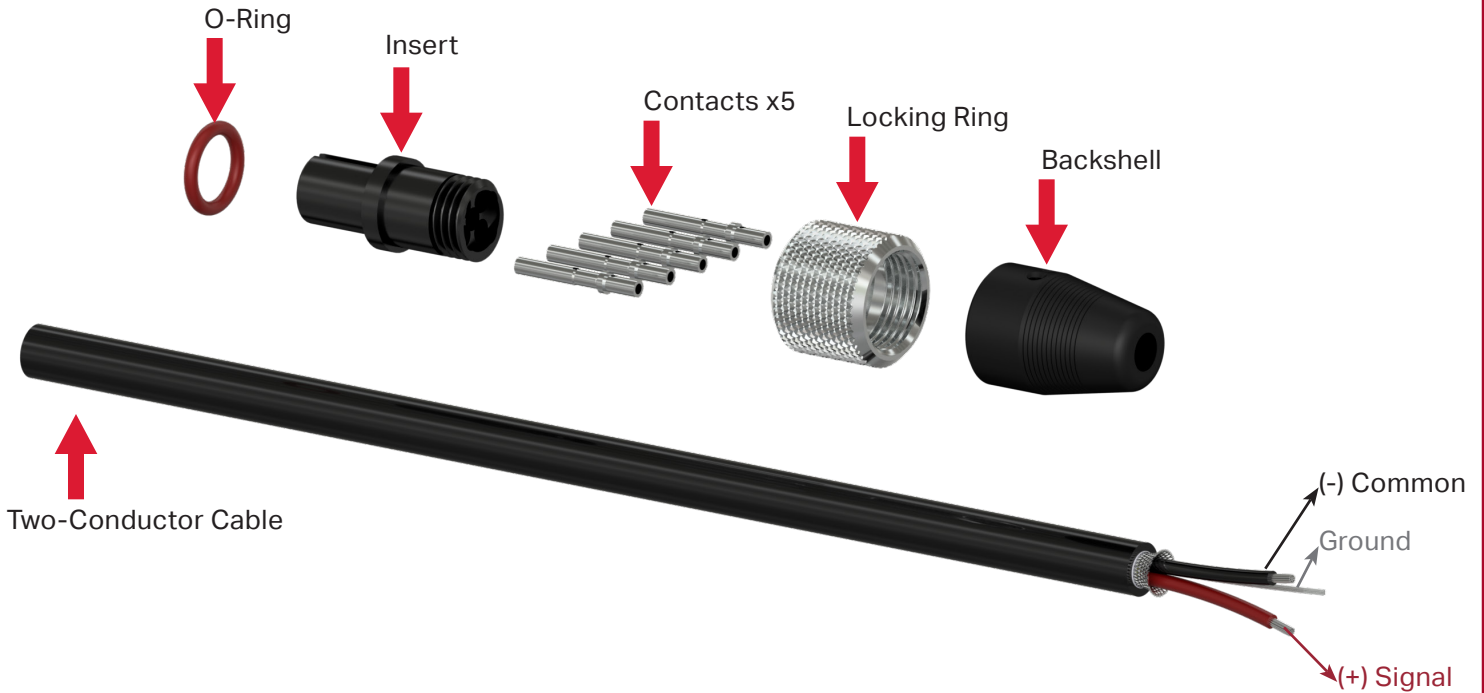

Figure 1. 2-Conductor Connector Kit Materials

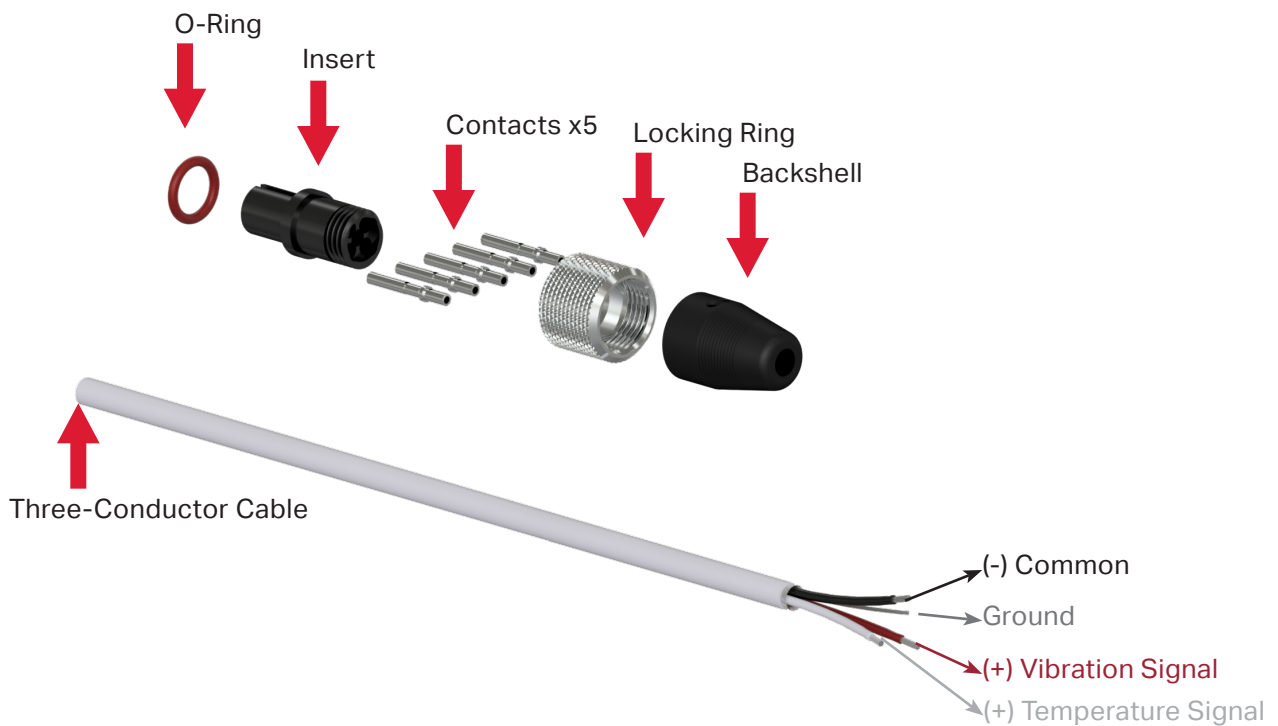

Figure 2. 3-Conductor Connector Kits Materials

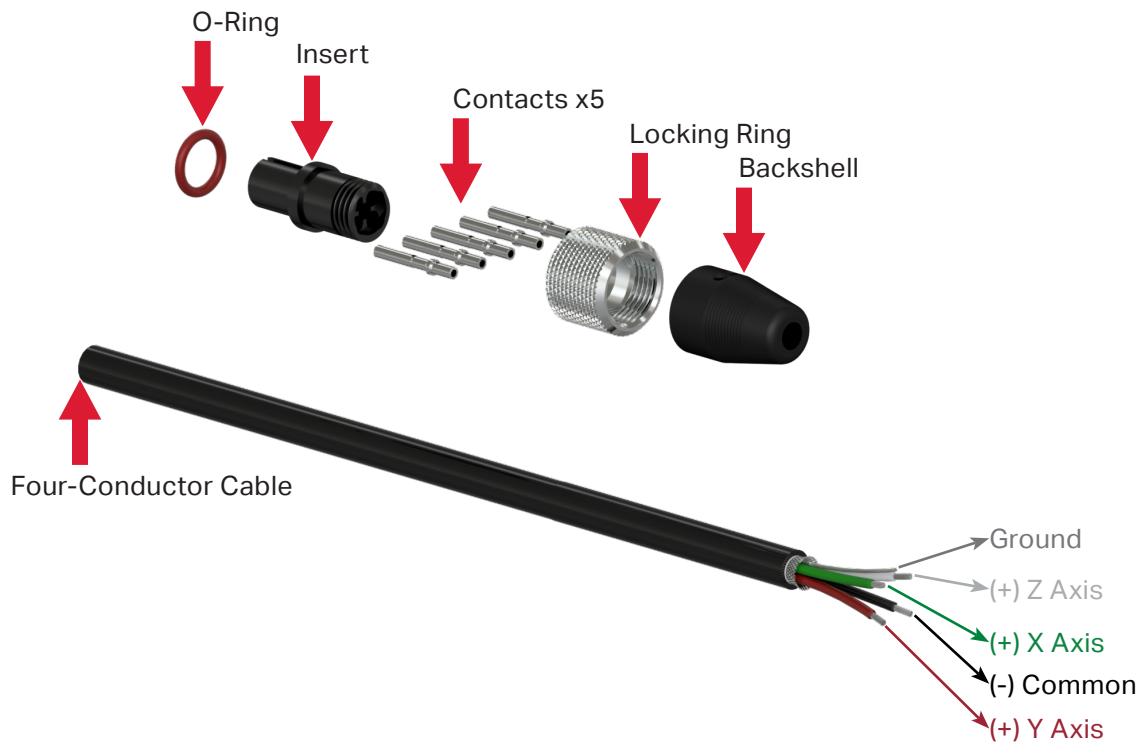

Figure 2. 4-Conductor Connector Kits Materials



Recommended Tool: CB926-1A



Recommended Epoxy: MH109-3D

Part #	Connector Kit Parts	Material	Max Temp	Connector Kit Parts #	Compatible Cables
M2A	 CK-M2A	Polycarbonate, 316L Stainless Steel Locking Ring	250 °F (121 °C)	CK-M2A-175	CB102 CB110
				CK-M2A-190	CB111
				CK-M2A-250	CB103 CB193 CB802 CB806 CB810 CB811
M2R	 CK-M2R	Polyphenylene Sulfide (PPS), 316L Stainless Steel Locking Ring	392 °F (200 °C)	CK-M2R-175	CB102
				CK-M2R-190	CB111
				CK-M2R-250	CB802 CB806 CB811
M3T	 CK-M3T	Polycarbonate, 316L Stainless Steel Locking Ring	250 °F (121 °C)	CK-M3T-175	CB112
				CK-M3T-250	CB105 CB119
				CK-M3T-310	CB218 CB612
M4A	 CK-M4A	Polycarbonate, 316L Stainless Steel Locking Ring	250 °F (121 °C)	CK-M4A-190	CB119
				CK-M4A-250	CB105 CB194 CB818 CB819
M4R	 CK-M4R	Polyphenylene Sulfide (PPS), 316L Stainless Steel Locking Ring	392 °F (200 °C)	CK-M4R-190	CB119
				CK-M4R-250	CB818 CB819

Table 1. Product Selection Guide

ASSEMBLY FOR CK-M2X SERIES

1. Strip outer jacket of wire 0.300 in.

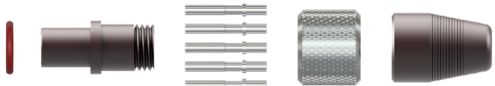
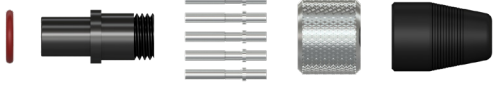
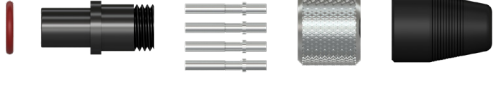
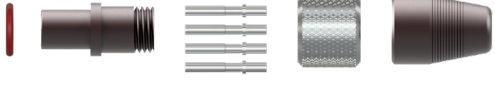
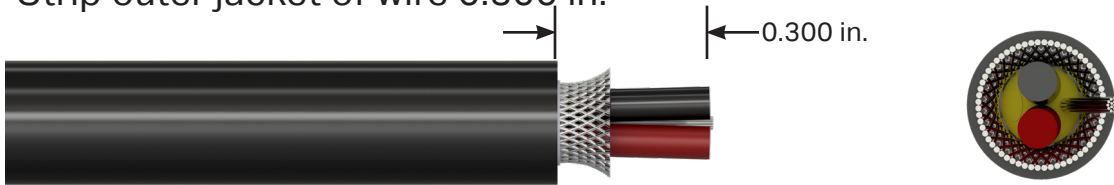

2. Cut off shield and drain wire (for twisted shielded pair wires only).



3. Strip the insulation of two conductor wires back 0.200 in.

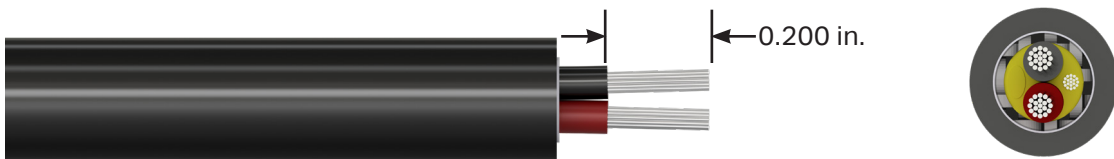

4. Crimp conductor wires into contact sockets. CTC's CB926-1A crimp tool makes crimping fast and easy and can lead to significant time savings when installing a large volume of connector kits. Adjusting the green depth knob to the desired length allows the depth of the contacts to be set manually to ensure a crimp at the correct location every time. Suggested depth for the "M" Series is 0.52 in.



5. Slide backshell and knurled ring onto the cable.



6. Attach O-ring to the front of the insert.

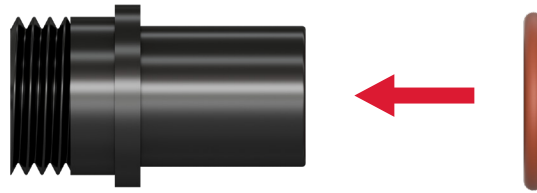

7. Using a fine-tipped punch, gently press each contact into the appropriate position on the insert.

- a. Install accelerometer red (+) wire into the insert socket for Pin 1.
- b. Install accelerometer black (-) wire into insert socket for Pin 2.
- c. Install the remaining pin contacts into the non-used spaces.

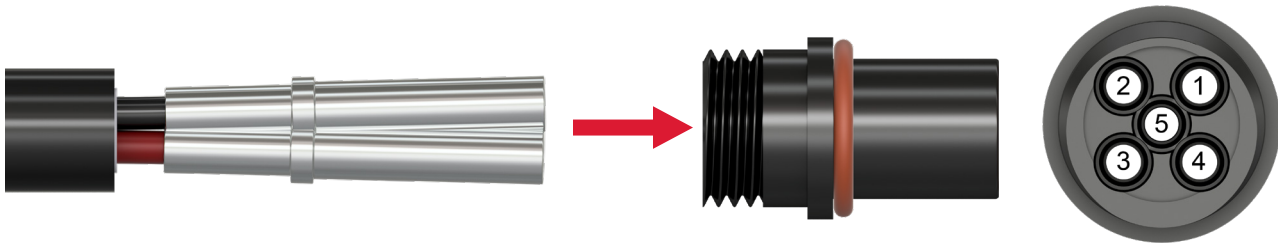

8. Slide the knurled ring over the threaded section of the insert until the metal step inside the ring catches on the plastic lip of the insert.



9. Thread the backshell onto the insert.

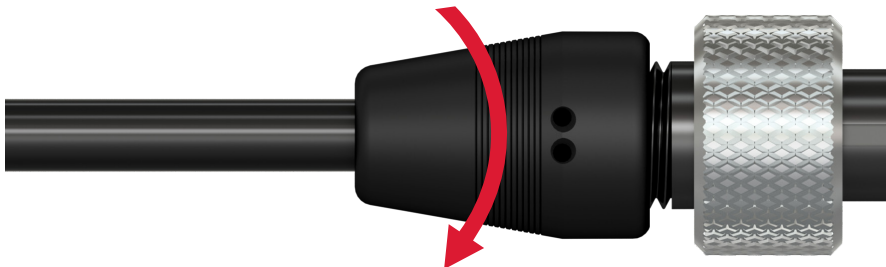

10. Place the assembled connector body horizontally with the two small epoxy injection holes level and facing upward.
11. Mix epoxy. Using a syringe, fill the backshell with epoxy through one of the small injection holes until epoxy begins to seep from the other.

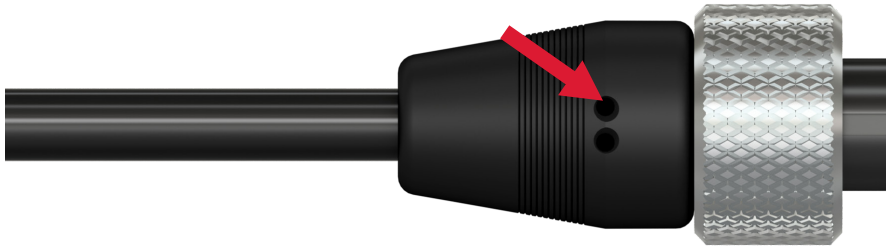

12. Keep the connector in a horizontal position, allowing the epoxy to set and vent any trapped air, refilling as needed.
13. Allow the epoxy to cure for six hours at room temperature. Place a piece of masking tape over the two epoxy holes to prevent leakage and hang the connector vertically with the insert facing downward. This will ensure epoxy encapsulates the cable evenly, especially if the cable diameter is smaller than the backshell opening.



ASSEMBLY FOR CK-M3X SERIES

1. Strip outer jacket of wire 0.300 in.

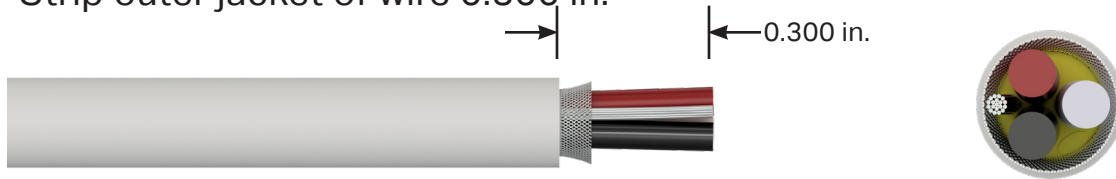

2. Cut off shield and drain wire (for twisted shielded pair wires only).

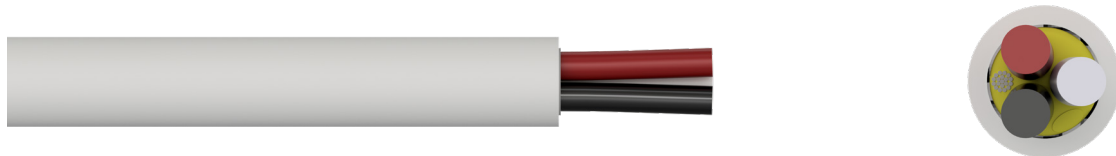

3. Strip the insulation of three conductor wires back 0.200 in.

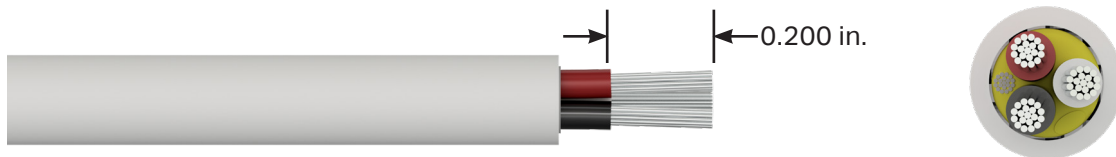

4. Crimp conductor wires into contact sockets. CTC's CB926-1A crimp tool makes crimping fast and easy and can lead to significant time savings when installing a large volume of connector kits. Adjusting the green depth knob to the desired length allows the depth of the contacts to be set manually to ensure a crimp at the correct location every time. Suggested depth for the "M" Series is 0.52 in.



5. Slide backshell and knurled ring onto the cable.



6. Attach O-ring to the front of the insert.

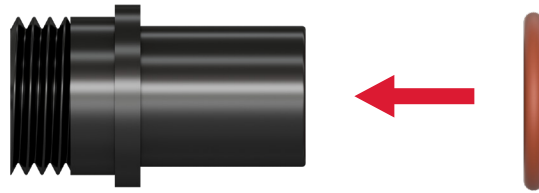

7. Using a fine-tipped punch, gently press each contact into the appropriate position on the insert.

- a. Install accelerometer red (+) wire into the insert socket for Pin 1.
- b. Install accelerometer black (-) wire into insert socket for Pin 2.
- c. Install accelerometer white (+) wire into the insert socket for Pin 3.
- d. Install the remaining pin contacts into the non-used spaces.

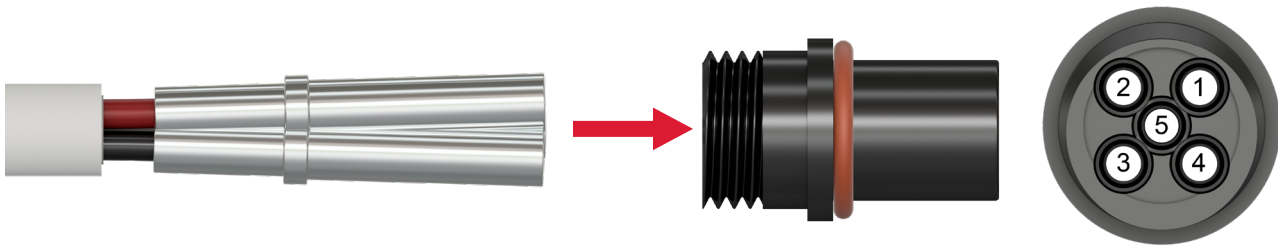

8. Slide the knurled ring over the threaded section of the insert until the metal step inside the ring catches on the plastic lip of the insert.



9. Thread the backshell onto the insert.

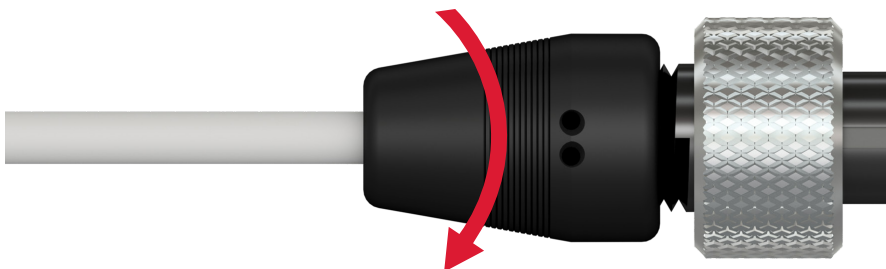

10. Place the assembled connector body horizontally with the two small epoxy injection holes level and facing upward.
11. Mix epoxy. Using a syringe, fill the backshell with epoxy through one of the small injection holes until epoxy begins to seep from the other.

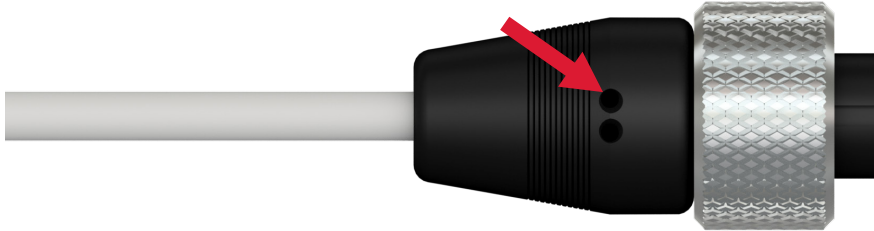

12. Keep the connector in a horizontal position, allowing the epoxy to set and vent any trapped air, refilling as needed.
13. Allow the epoxy to cure for six hours at room temperature. Place a piece of masking tape over the two epoxy holes to prevent leakage and hang the connector vertically with the insert facing downward. This will ensure epoxy encapsulates the cable evenly, especially if the cable diameter is smaller than the backshell opening.



ASSEMBLY FOR CK-M4X SERIES

1. Strip outer jacket of wire 0.300 in.

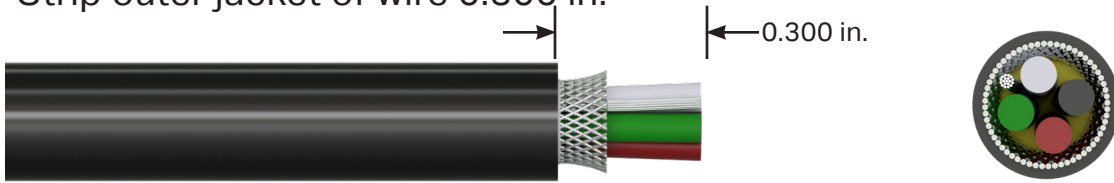

2. Cut off shield and drain wire (for twisted shielded pair wires only).

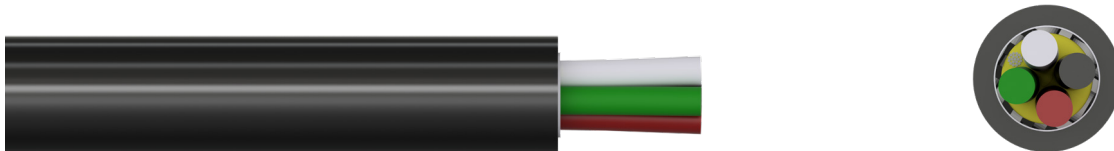

3. Strip the insulation of three conductor wires back 0.200 in.

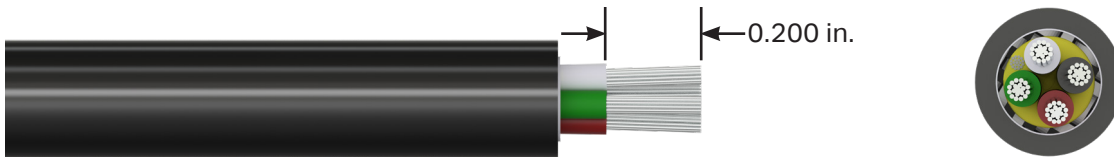

4. Crimp conductor wires into contact sockets. CTC's CB926-1A crimp tool makes crimping fast and easy and can lead to significant time savings when installing a large volume of connector kits. Adjusting the green depth knob to the desired length allows the depth of the contacts to be set manually to ensure a crimp at the correct location every time. Suggested depth for the "M" Series is 0.52 in.



5. Slide backshell and knurled ring onto the cable.

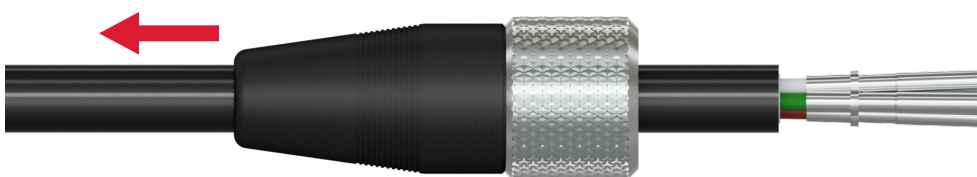

6. Attach O-ring to the front of the insert.

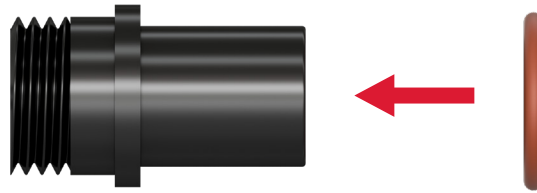

7. Using a fine-tipped punch, gently press each contact into the appropriate position on the insert.
- a. Install accelerometer red (+) wire into the insert socket for Pin 1.
 - b. Install accelerometer green (+) wire into insert socket for Pin 2.
 - c. Install accelerometer white (+) wire into insert socket for Pin 3.
 - d. Install accelerometer black (-) wire into insert socket for Pin 4.
 - e. Install the remaining pin contact into the non-used space.

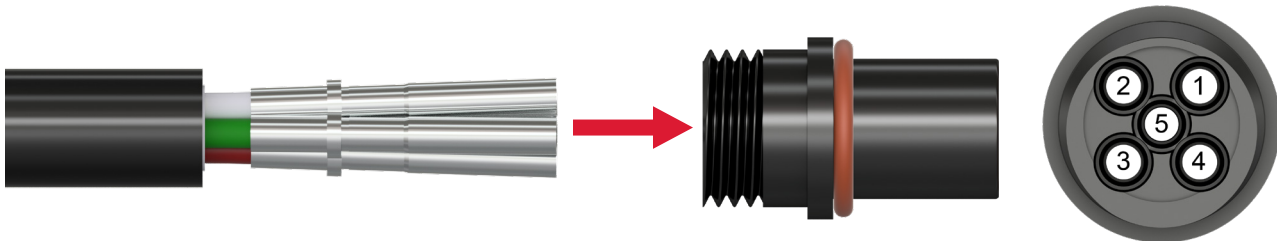

8. Slide the knurled ring over the threaded section of the insert until the metal step inside the ring catches on the plastic lip of the insert.



9. Thread the backshell onto the insert.

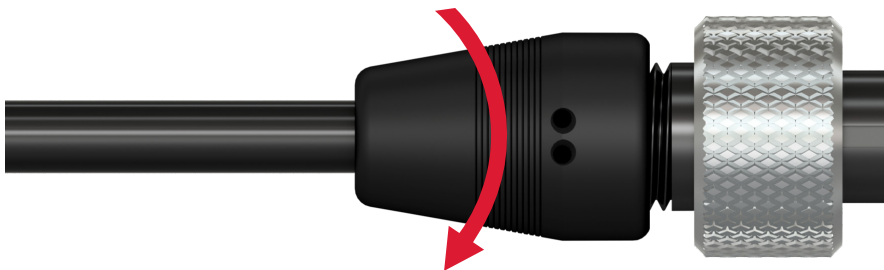

10. Place the assembled connector body horizontally with the two small epoxy injection holes level and facing upward.
11. Mix epoxy. Using a syringe, fill the backshell with epoxy through one of the small injection holes until epoxy begins to seep from the other.

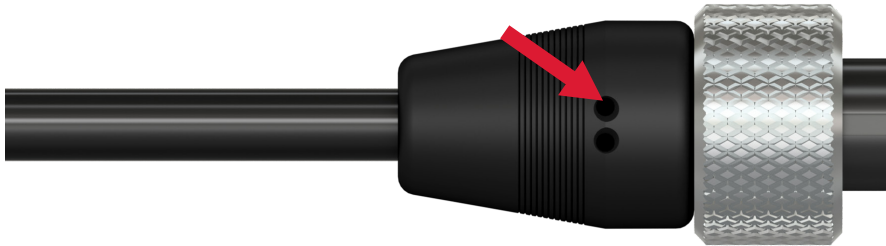

12. Keep the connector in a horizontal position, allowing the epoxy to set and vent any trapped air, refilling as needed.
13. Allow the epoxy to cure for six hours at room temperature. Place a piece of masking tape over the two epoxy holes to prevent leakage and hang the connector vertically with the insert facing downward. This will ensure epoxy encapsulates the cable evenly, especially if the cable diameter is smaller than the backshell opening.



MAINTENANCE

Once the product has been installed, minimal maintenance will be required. Basic visual checks to ensure integrity should be made periodically.

General

There are no customer-replaceable parts. The product has been designed for trouble-free service under normal operating conditions.

WARRANTY & REFUND

Please visit www.ctconline.com to view a complete recapitulation of our warranty and refund policies.

CONTACT INFORMATION

Connection Technology Center, Inc. (CTC)

7939 Rae Blvd.

Victor, NY 14564

1.585.924.5900

sales@ctconline.com

www.ctconline.com

